

SILICON PHOTODIODES

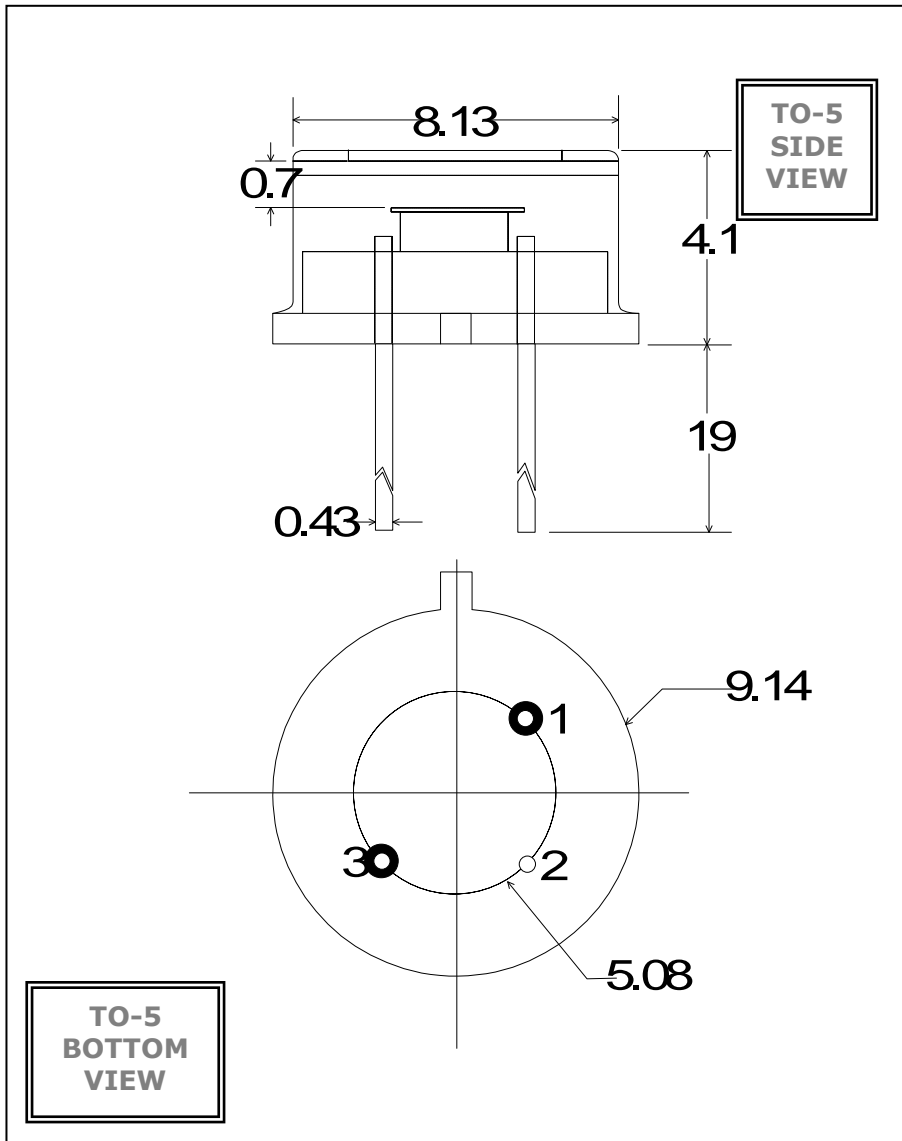

PIN OUT

- 1 = ANODE
- 2 = CASE
- 3 = CATHODE

Note:

Dimensions in millimeters

Application Note

ELECTRO OPTICAL SYSTEMS offers room temperature photodiode detectors. The units have state-of-the-art sensitivity and may be supported by accessories such as optical filters (longpass and bandpass), integral preamplifiers, and fiber optic connectors. These units find applications in industrial control systems, gas analyzers, thermal sensors, and general fiber optic test instrumentation.

SPECIFICATIONS

Part Number	UVS - 025
Active Diameter (mm)	2.5 mm
Operating Wavelength - nm	200 - 1000
Shunt Resistance (Ω)	500 M
Shunt Capacitance (pF) - typ	400
Responsivity (A/W) - min	.55 @ 750 nm
NEP ($W/Hz^{1/2}$) - @ 100Hz	$<1.0 \times 10^{-14}$

RoHS Compliant